

DRAWING MADE IN THIRD ANGLE PROJECTION

3

2

1

LOC 2 DIST 37

THIS DRAWING IS UNPUBLISHED. RELEASED FOR PUBLICATION
 © COPYRIGHT 19 BY AMP INCORPORATED, HARRISBURG, PA. ALL INTERNATIONAL RIGHTS RESERVED. AMP PRODUCTS MAY BE COVERED BY U.S. AND FOREIGN PATENTS AND/OR PATENTS PENDING.

REVISIONS					
P	F	ZONE	LTR	DESCRIPTION	DATE APPROVED
			D	RELEASED WAS SK-01930A-1	RN 7/14/81
			A	.75 WAS .38.	RPH 7/20/81
			B	REV. ADDED MORE INFO.	RN 7/20/81
			C	REV. PICTORIALY	RN 7/20/81

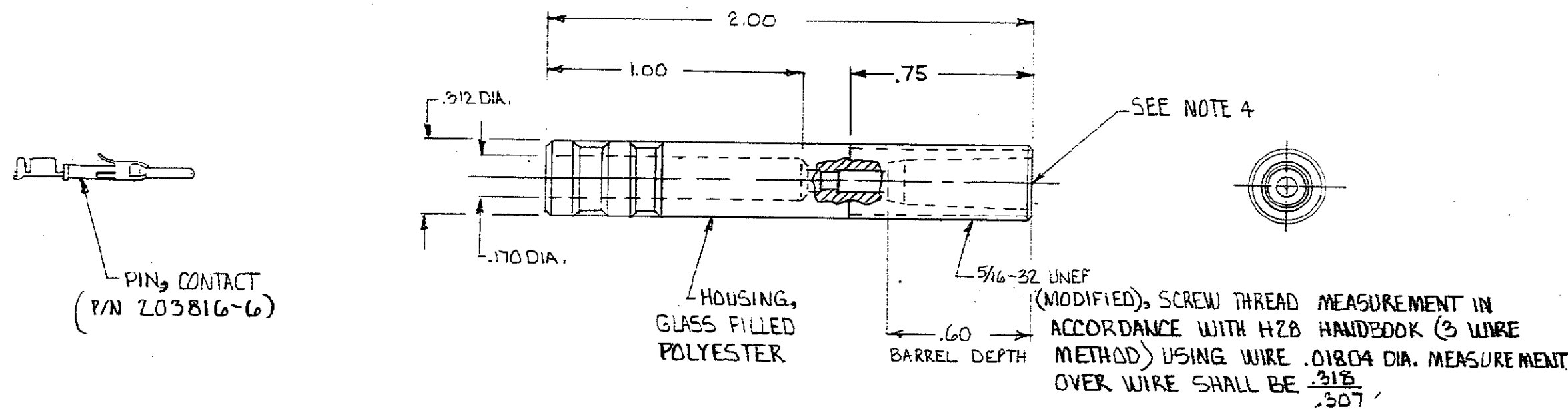

1. CONTACT TO ACCEPT #20-#22 AWG WIRE, WITH MAX. INSULATION DIA. OF .160
2. HAND TOOL: AMP # 90260-1
3. EXTRACTION TOOL: # 91038-3
4. TO MATE WITH AMP P/N 867160

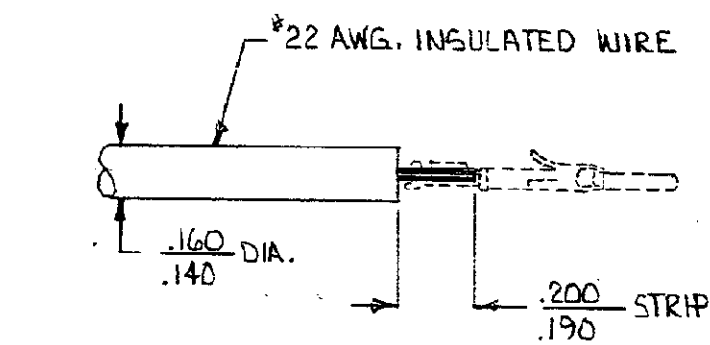

CUSTOMER WIRE PREPARATION

867156-1 AS SHOWN

UNLESS OTHERWISE SPECIFIED DIMENSIONS ARE IN INCHES. TOLERANCES ON: DECIMALS .XX ± .03 ANGLES .XX ± .015		CONTRACT NO		AMP INCORPORATED Harrisburg, Pa. 17105	
MATERIAL		DR <i>B. May</i> 7-6-81		NAME	
FINISH		CHK		COMMERCIAL RECEPTACLE KIT	
		APPD <i>M. Gardner</i> 7/8/81		LGH	
		DSGN APPD		SIZE C	FSCM NO 00779
		OTHER APPD		DRAWING NO 867156	
		SCALE ~		SHEET 1 of 1 REV C	

CUSTOMER DRAWING